

PRODUCT INFORMATION

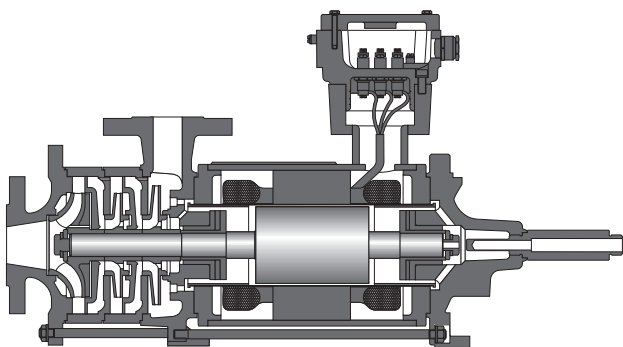

Multistage canned motor pumps

Model series CAM/CAM-Tandem

## Contents

Description .....	2
Application and insertion .....	4
Functional principle and materials .....	5
Design options .....	11
Monitoring systems .....	13
Characteristics diagram .....	14

## Description

### General

Canned motor pumps are characterised by a compact, integrated unit without mechanical seal. The motor and pump form a unit with the rotor and the impeller fitted onto a common shaft. The rotor is guided by two identical, medium-lubricated slide bearings. The stator on the drive motor is separated from the rotor space using a thin stator liner. The rotor cavity itself, along with the hydraulic section of the pump, create a combined cavity which needs to be filled with pumping medium before commissioning.

The heat loss from the motor is carried off by a partial flow between the rotor and the stator. At the same time, the partial flow lubricates both slide bearings in the rotor cavity. Both the can, which is a hermetically sealed component, and the motor casing are used as a safety containment. Because of that, canned motor pumps always ensure highest safety level when conveying dangerous, toxic, explosive and valuable media.

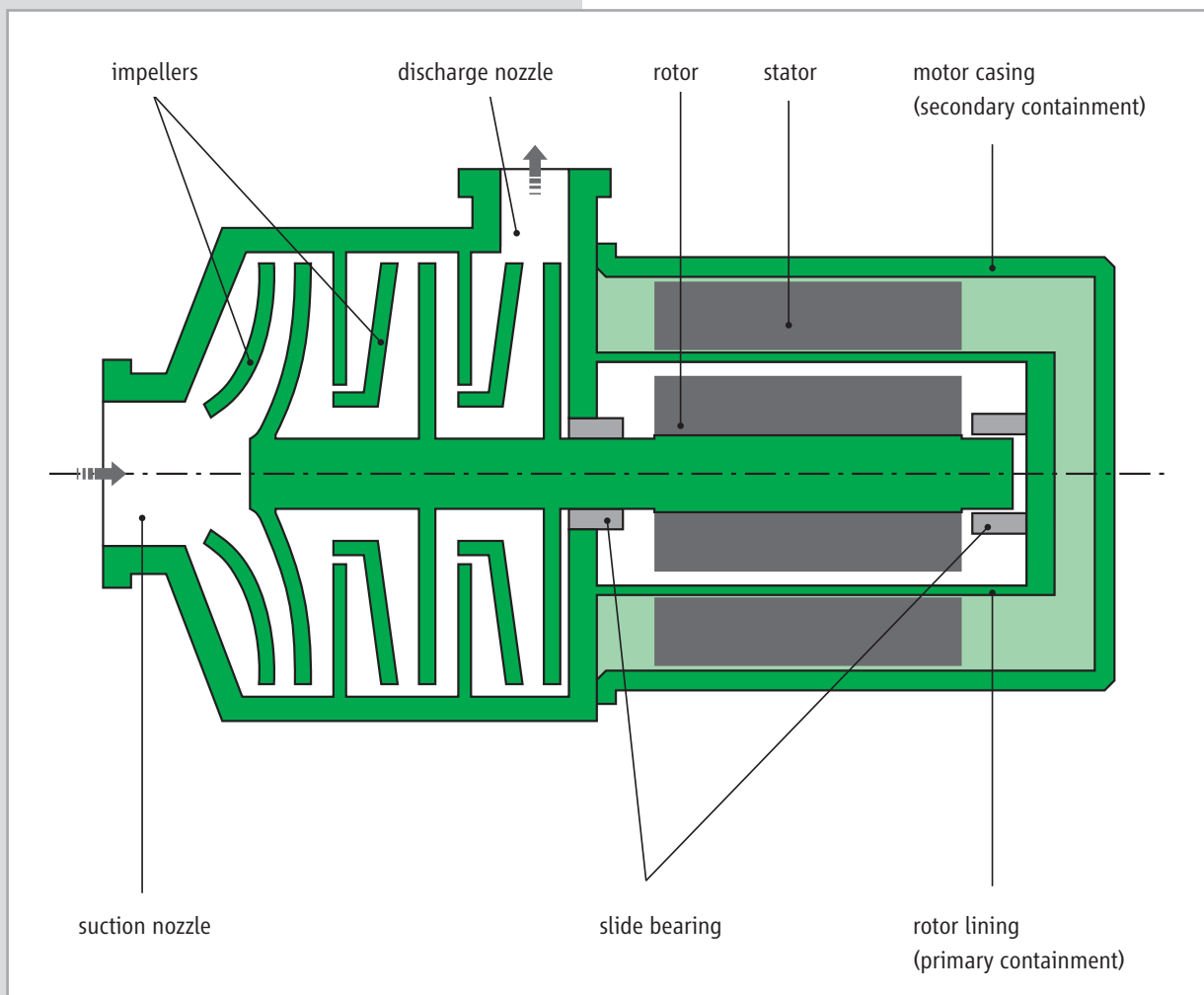

## Function

### CAM

The pump output is delivered through the impellers and diffusers arranged one behind the other to the pressure nozzle and in this way an increase in pressure is achieved depending on the number of stages. The partial flow for cooling the motor and lubricating the slide bearings is tapped off on pressure side after the last impeller and after flowing through the motor is lead out again through the hollow shaft between the stages. Since, as a result, no heated part of the delivery flows back to the suction side considerably more stable NPSH values are produced in the part load range. Aggregates of multistage design can therefore be used for considerably smaller pumping capacities, than pumps of single-stage design.

### CAM-Tandem

Very high pressure differences with compact design can be achieved with this set in which the stages are arranged on both sides of the canned motor. The total quantity pumped flows through the canned motor and at the same time carries away the motor heat losses. Since, as a result, no heated part of the delivery flows back to the suction side considerably more stable NPSH values are produced in the part load range. Aggregates of Tandem design can therefore be used for considerably smaller pumping capacities, than pumps of single-stage design.

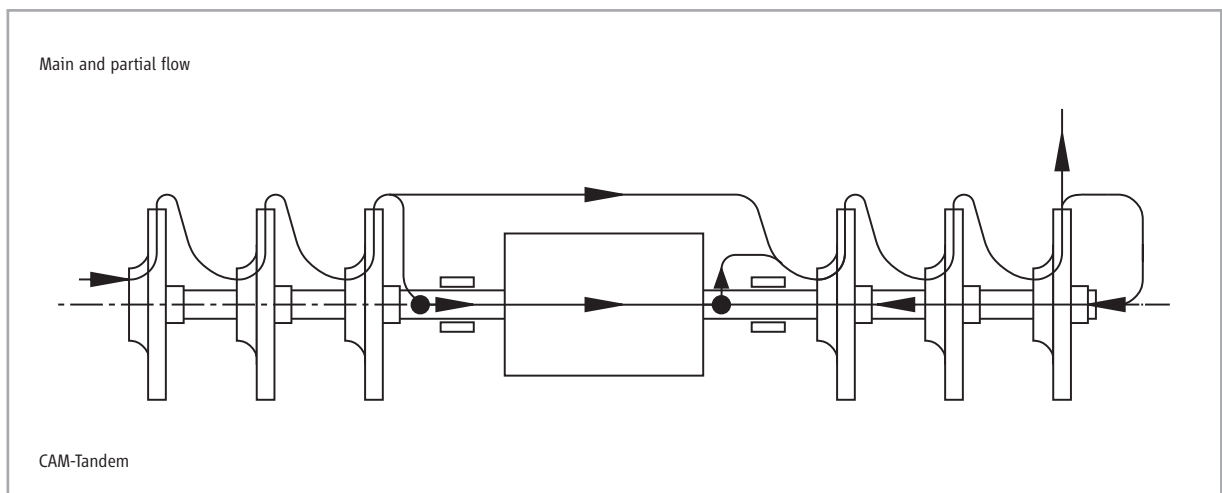
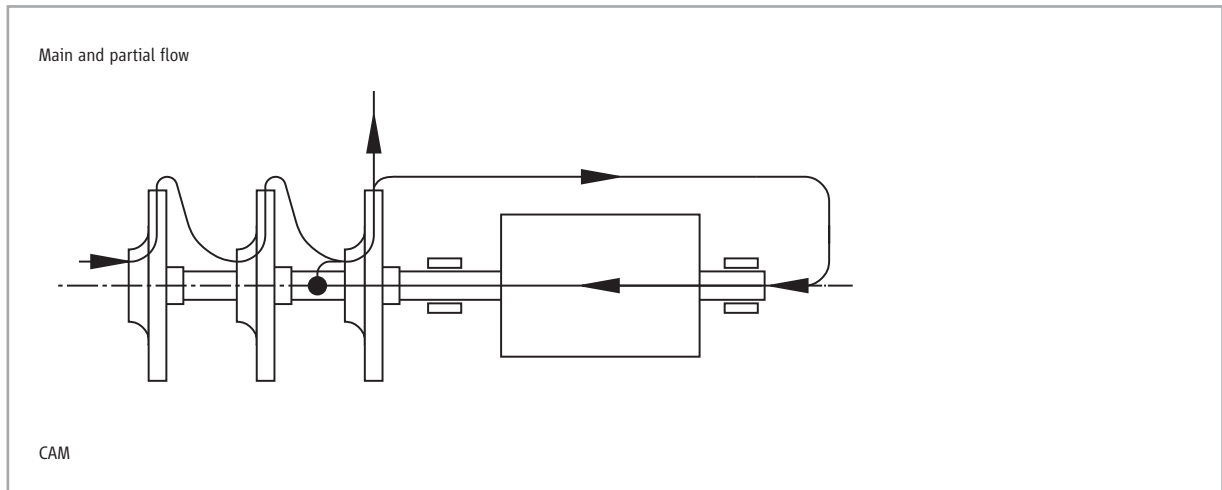

# Application and insertion

## Application sector

### CAM/CAM-Tandem

For pumping aggressive, poisonous, explosive, expensive, inflammable, radioactive and also easily vaporised fluids, for example sulphuric acid, nitric acid, hydrofluoric acid, hydrocyanic acid, phosgene, dimethyl sulphate, vinyl chloride, ether, amine, ethylene chloride, propane, butane, propylene, chlorine, D<sub>2</sub>O, etc.

## Application ranges

CAM 1:	– 120 °C to + 100 °C
CAM 2:	– 120 °C to + 360 °C
CAM 30:	– 120 °C to + 360 °C
CAM 32:	– 120 °C to + 360 °C
CAM 44 to 64:	– 120 °C to + 360 °C
CAM-Tandem:	– 120 °C to + 360 °C

## Canned motors

Power:	up to 325 kW
Operation:	S1 to S10
Voltage:	400 / 690 V (special tensions possible)
Heat class:	H – 180 C – 220 / C – 400
Frequency:	50 or 60 Hz (plus frequency converter operation on request)
Protections:	motor IP 68 terminal box IP 55
Motor protection:	thermistor e.g. KL 180 (for H-winding) PT 100 (for C-winding)

## Explosion protection

according to EC design test certificate in line with Directive 94/9/EC ATEX  II 2 G EEx dec II C T1 to T6

## Documentation

Digital standard documents (CD-ROM) adapted to CE requirements include:

- sectional drawing
- dimensional drawing
- EC conformity declaration
- operating instructions

## Pump and hydraulic denomination

Model series CAM e.g.

### CAM XX 44 / 6

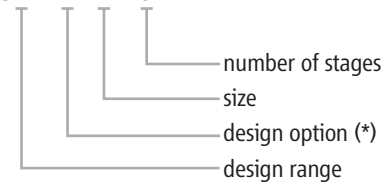

(\*) possible design options

H = high pressure design

K = with separate heat exchanger

T = barrel design

V = vertical design

Model series CAM-Tandem e.g.

### CAM XX 44 / 3 + 2

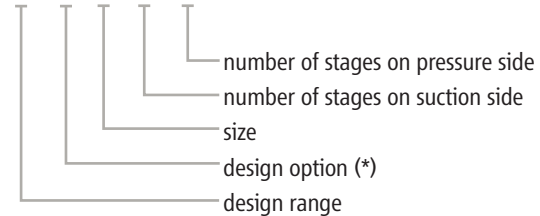

(\*) possible design options

H = high pressure design

T = barrel design

V = vertical design

## Inspections and guarantees

### Standard inspections

Hydraulic inspection:

- each pump is subject to a test run and the operating point is guaranteed according to ISO 9906 – class 2 (5 measuring points)
- pressure test
- axial thrust measurement
- leak test (nitrogen filling)

### Additional inspections

The following inspections can be carried out and certified against additional price (e.g. NPSH test, Helium leakage test, vibration test, ultrasonic test, PMI test). Any further inspections and tests are according to the technical specification. The guarantees are effected according to the valid conditions of supply.

## Functional principle and materials

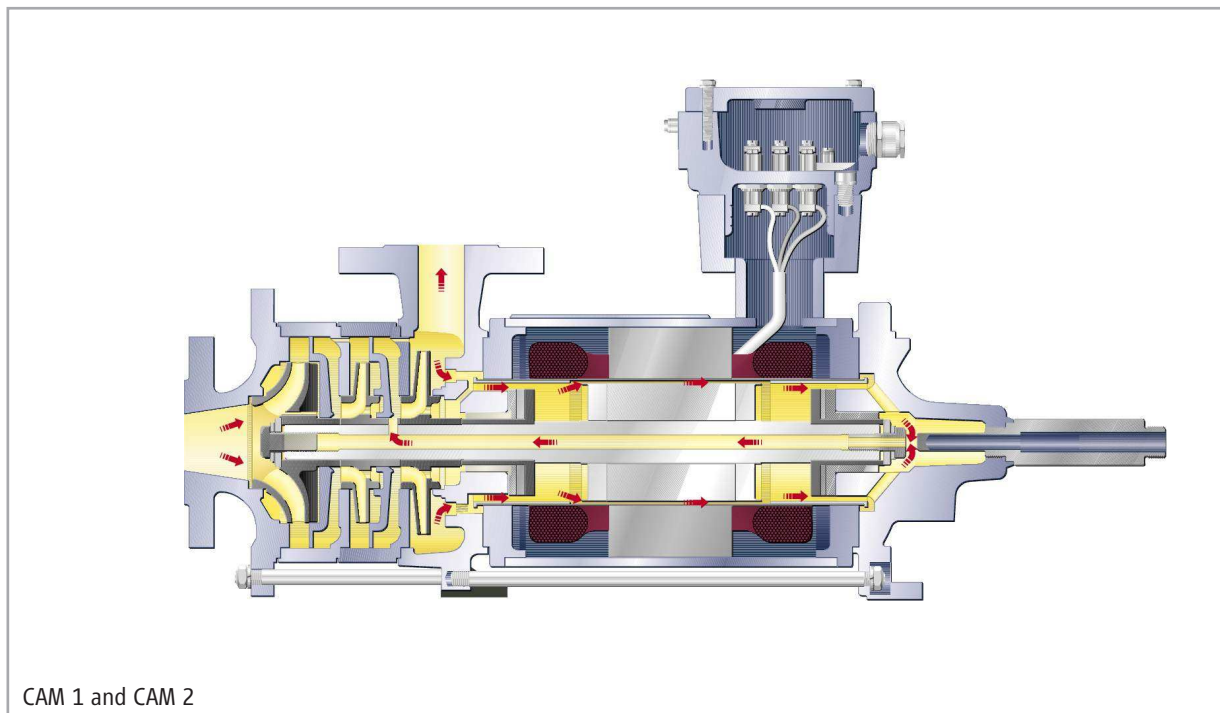

### Materials and pressure ratings

VDMA-no.	description	model range CAM 1 and CAM 2		
		material S1	material S2	material C
		pressure rating CAM 1: PN 25 CAM 2: PN 25	pressure rating CAM 2: PN 25 to PN 40	pressure rating CAM 1: PN 25 CAM 2: PN 25 to PN 40
<b>wetted parts</b>				
101	pump casing	JS 1025	1.0619+N	1.4581 / 1.4571
108	stage casing	1.0460	1.0460	1.4571
162	suction cover	JS 1025	1.0460	1.4581 / 1.4571
174	diffuser insert	JL 1030	JL 1030	1.4581
230	impellers	JL 1030	JL 1030	1.4581
529.01/02	bearing sleeve	1.4571/W5 <sup>(1)</sup>	1.4571/W5 <sup>(1)</sup>	1.4571/W5 <sup>(1)</sup>
545.01/02	bearing bush	1.4571/SiC30	1.4571/SiC30	1.4571/SiC30
816	stator can	Hastelloy C4	Hastelloy C4	Hastelloy C4
817	rotor lining	1.4571	1.4571	1.4571
819	motor shaft	1.4021 / 1.4571	1.4021 / 1.4571	1.4571
<b>non-wetted parts</b>				
811	motor casing	1.0570 / 1.0037	1.0037	1.0570 / 1.0037

special materials / higher pressure ratings are possible on demand

(1) denotes Tungsten carbide coating

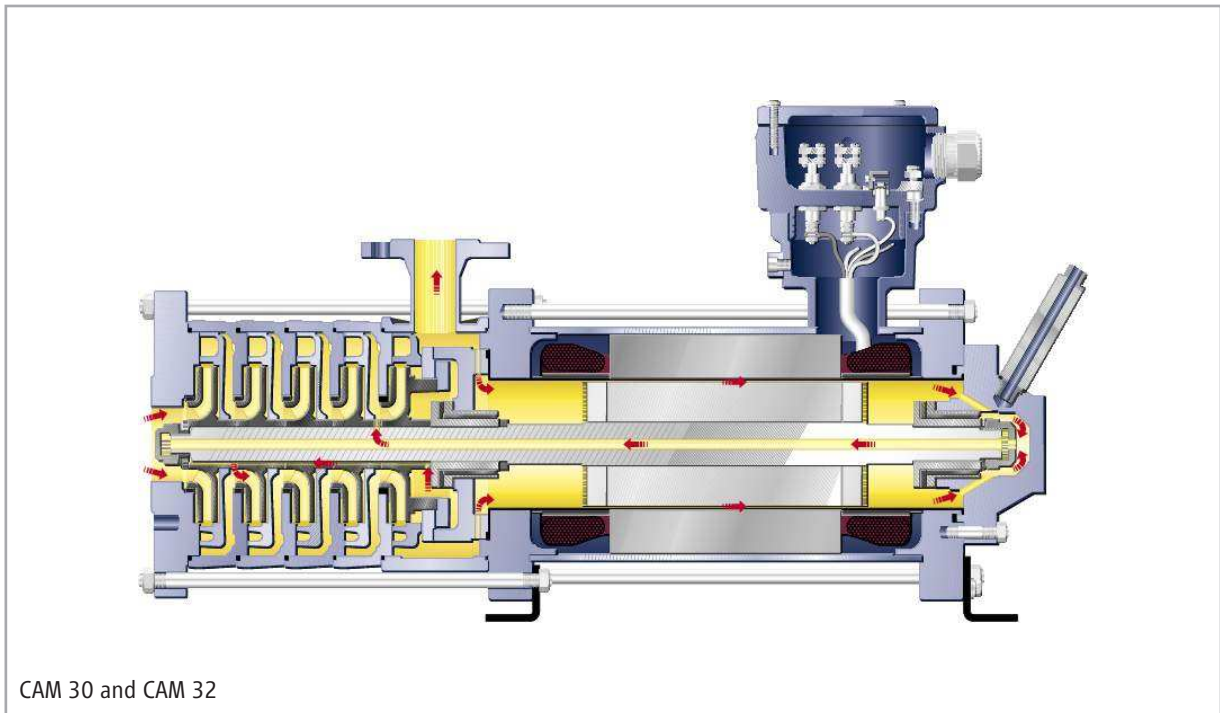

CAM 30 and CAM 32

### Materials and pressure ratings

VDMA-no.	description	model range CAM 30 and CAM 32	
		material S2	material C
		pressure rating PN 25 to PN 64	pressure rating PN 25 to PN 64
<b>wetted parts</b>			
101	pump casing	1.0460	1.4571
108	stage casing	1.0460	1.4571
162	suction cover	1.0570	1.4571
174	diffuser insert	JS 1030	1.4408
230	impellers	JS 1030	1.4408
512	balancing ring	JL 1030	0.7660 / 1.4462
529.01/02	bearing sleeve	1.4571/W5 <sup>(1)</sup>	1.4571/W5 <sup>(1)</sup>
545.01/02	bearing bush	1.4571/SiC30	1.4571/SiC30
816	stator can	Hastelloy C4	Hastelloy C4
817	rotor lining	1.4571	1.4571
819	motor shaft	1.4021	1.4571
<b>non-wetted parts</b>			
811	motor casing	1.0254	1.0254

special materials / higher pressure ratings are possible on demand

(1) denotes Tungsten carbide coating

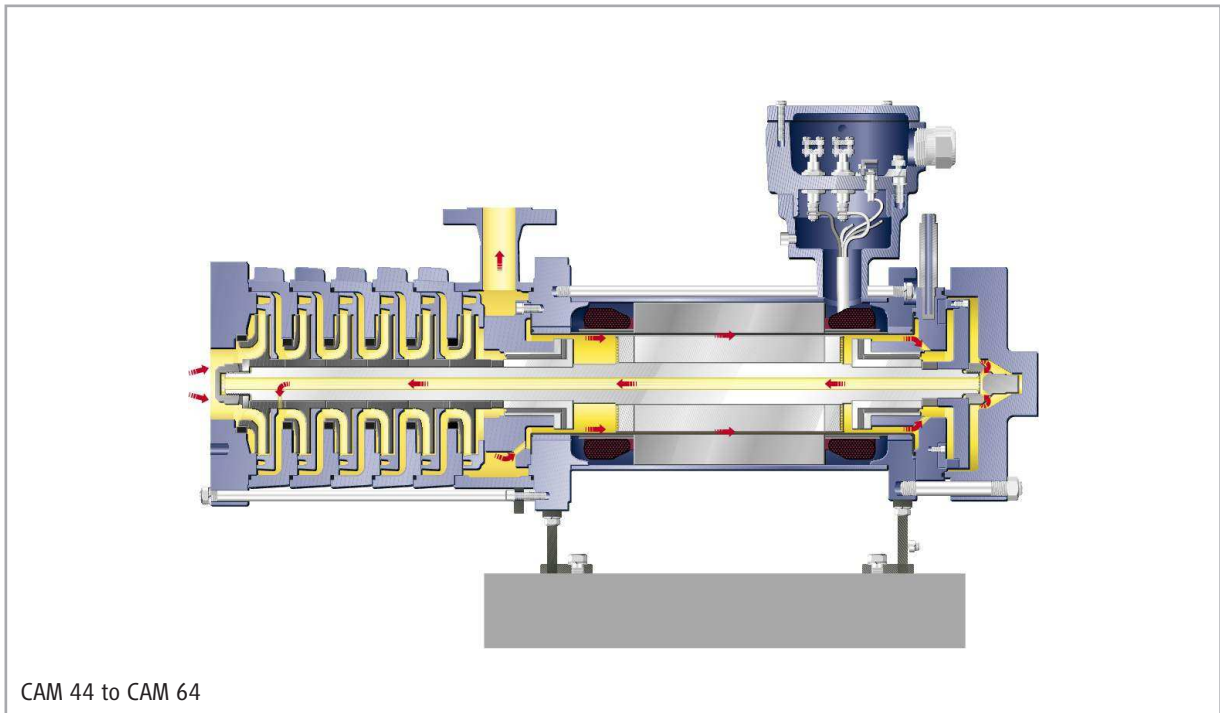

### Materials and pressure ratings

VDMA-no.	description	model range CAM 44 to CAM 64	
		material S2	material C
		pressure rating PN 25 to PN 64	pressure rating PN 25 to PN 64
<b>wetted parts</b>			
101	pump casing	1.0460 <sup>(2)</sup> / 1.0570	1.4571
108	stage casing	1.0619	1.4408
162	suction cover	1.0570	1.4571
174	diffuser insert	JL 1030	1.4408
230	impellers	JL 1030 <sup>(2)</sup> / 1.4008	1.4408
512	balancing ring	JL 1030	0.7660 / 1.4462
529.01/02	bearing sleeve	1.4571/W5 <sup>(1)</sup>	1.4571/W5 <sup>(1)</sup>
545.01/02	bearing bush	1.4571/SiC30	1.4571/SiC30
816	stator can	Hastelloy C4	Hastelloy C4
817	rotor lining	1.4571	1.4571
819	motor shaft	1.4021	1.4571
<b>non-wetted parts</b>			
811	motor casing	1.0254	1.0254

special materials / higher pressure ratings are possible on demand

(1) denotes Tungsten carbide coating

(2) only possible for CAM 44 and CAM 52

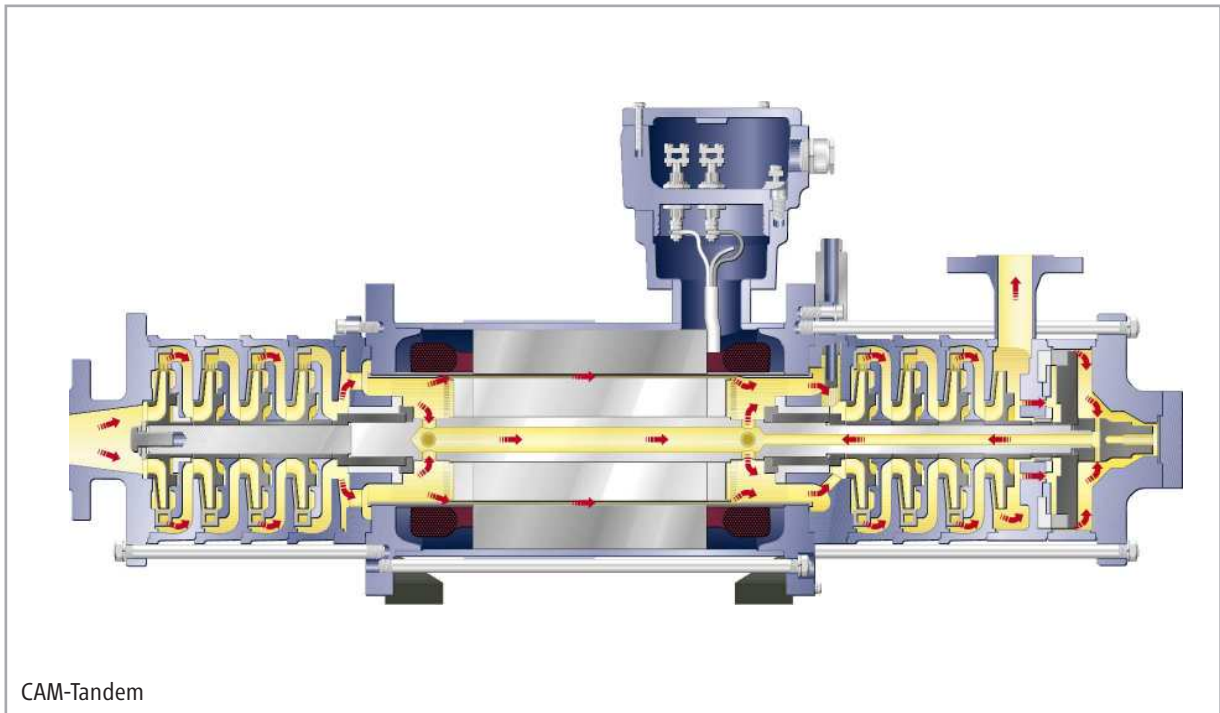

### Materials and pressure ratings

VDMA-no.	description	model range CAM-Tandem		
		material S1	material S2	material C
		pressure rating PN 25	pressure rating PN 25 to PN 64	pressure rating PN 25 to PN 64
<b>wetted parts</b>				
101	pump casing	JS 1025	1.0619+N / 1.0460 / 1.0570	1.4581 / 1.4571
108	stage casing	1.0460	1.0460 / 1.0619	1.4571 / 1.4408
162	suction cover	JS 1025	1.0460 / 1.0570	1.4581 / 1.4571
174	diffuser insert	JL 1030	JL 1030 / JS 1030	1.4581 / 1.4408
230	impellers	JL 1030	JL 1030 / JS 1030 / 1.4008	1.4581 / 1.4408
529.01/02	bearing sleeve	1.4571/W5 <sup>(1)</sup>	1.4571/W5 <sup>(1)</sup>	1.4571/W5 <sup>(1)</sup>
545.01/02	bearing bush	1.4571/SiC30	1.4571/SiC30	1.4571/SiC30
816	stator can	Hastelloy C4	Hastelloy C4	Hastelloy C4
817	rotor lining	1.4571	1.4571	1.4571
819	motor shaft	1.4021 / 1.4571	1.4021 / 1.4571	1.4571
<b>non-wetted parts</b>				
811	motor casing	1.0570 / 1.0037	1.0037 / 1.0254	1.0570 / 1.0037 / 1.0254

special materials / higher pressure ratings are possible on demand

(1) denotes Tungsten carbide coating



### Bearing arrangement

The bearing in hermetically designed pumps must be located and immersed in the operating liquid. Therefore, in most cases, only the use of hydrodynamic slide bearings is required. The correct operating method ensures the advantage that no contact may be created between the bearing lining. Thus, they are constantly running free from wear and maintenance. Service life of 8 to 10 years can be easily achieved by using HERMETIC pumps.

The almost universal bearing combination based on tungsten carbide (W5) and silicon carbide (SiC30) has to be proved to be the best choice. These combinations consist of metallic shaft sleeves made of stainless steel (1.4571) and coated

by tungsten carbide according to the "High Velocity Oxygen Fuel Procedure". Furthermore, they consist of a firm bearing bush made of ceramic material (SiC30) that is surrounded by a sleeve made of stainless steel. SiC30 is a mixed material of silicon carbide and graphite, combining the product advantages of both materials. Conditions of mixed friction, as they may arise for example during start-up and stopping phase of pumps, can be easily handled with SiC30. Moreover, this material is deemed to be thermal shock resistant (high resistance against changes in temperature), as well as chemically stable and blister resistant (no formation of bubbles at material surface) and abrasion resistant.

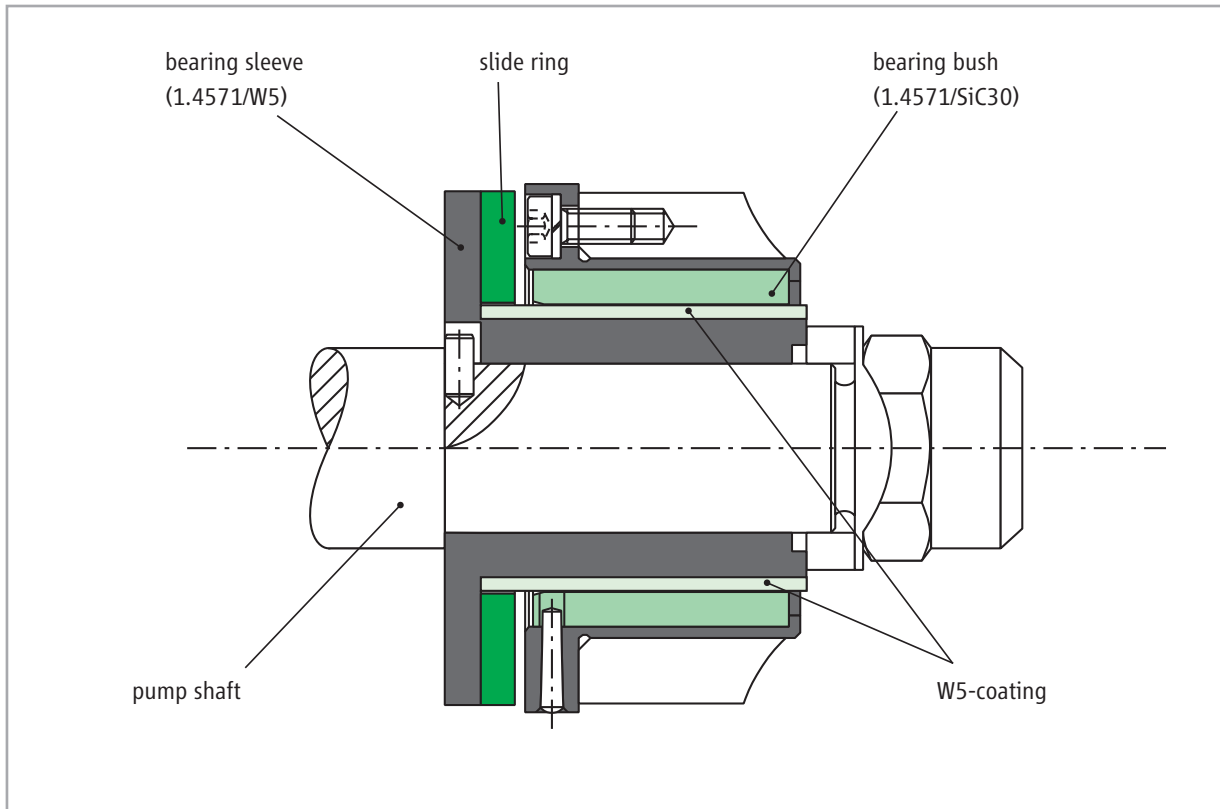

### **Axial thrust balancing**

The development of HERMETIC pump systems depended on the solution of a central problem, namely the elimination of axial thrust at the rotor equipment. The various fluid properties exclude the possibility of using mechanical axial bearings. The only generally valid solution to this problem thus lay in hydraulic balance of the rotor.

With canned motor pumps the axial position of the pump shaft is automatically regulated during operation to achieve a self-created balanced condition and thus, there are no effects by axial forces on the axial bearing collar.

The technical design of the axial thrust balancing generally depends on the construction size and stage number of the respective pump as well as on the liquid to be conveyed.

### **Example:**

#### **Pump size CAM 1 and CAM 2**

The axial thrust balancing is effected by back vanes and balancing borings on the first impeller.

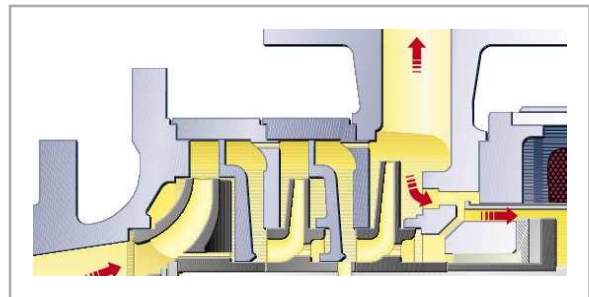

#### **Pump size CAM 30 and CAM 32**

The axial thrust balancing is guaranteed by a balancing disc (pump side arrangement) and balancing borings.

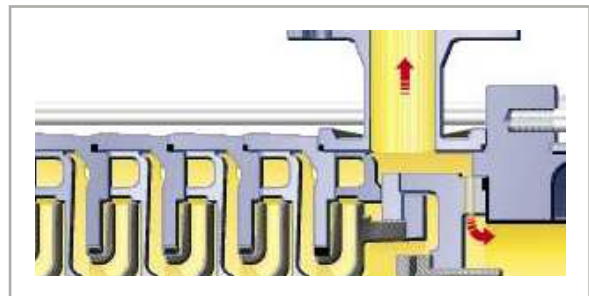

#### **Pump size CAM 44 to CAM 64**

The axial thrust balancing is guaranteed by a balancing disc (motor side arrangement) and balancing borings.

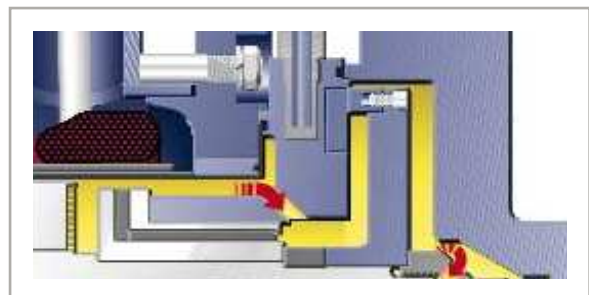

## Design options

### High system pressures

High system pressures (up to 1200 bar) can be handled by canned motor pumps in a technically simple manner. The wall thickness of the outer components corresponds to the required pressure rate.

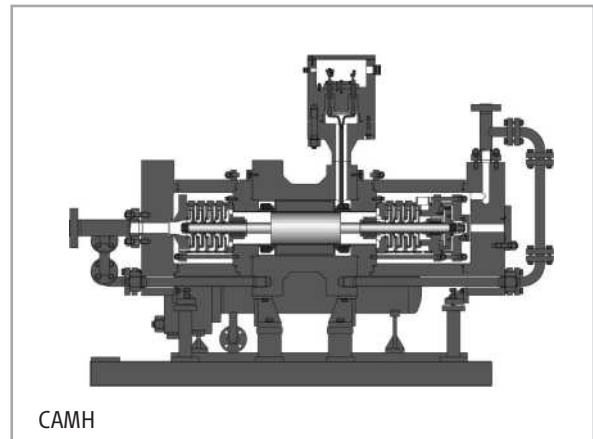

### High temperature design

The external cooling of the pump allows the application of liquids to be conveyed up to +400°C. By default, when conveying these liquids, tubular coolers are used, but also plate coolers or air coolers can be used according to the production and plant conditions.

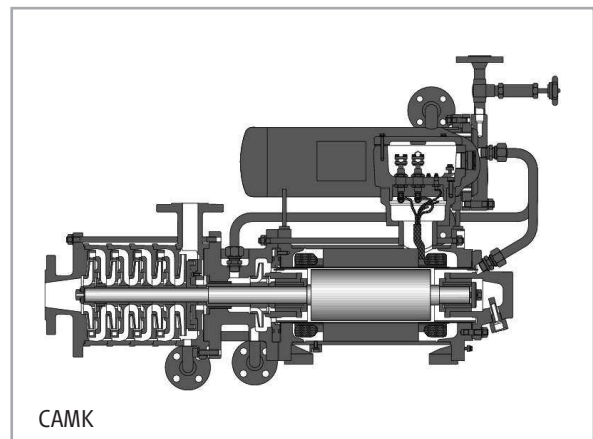

### Barrel design

The number of stages determines the number of the required static gaskets. By using pressure barrels, this number can be reduced. Moreover, through the use of pressure barrels, higher system pressures can be achieved.

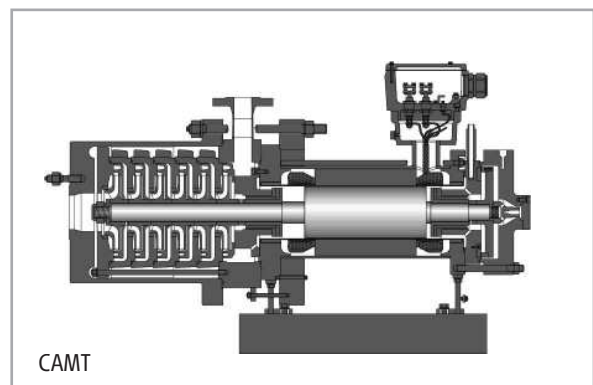

**Pressure gases / liquefied gases**

Due to the low viscosity and the resulting reduced capacity of the slide bearings, the pump can be erected vertically. In this case, the slide bearings do not have support properties, but only a leading function. The rotor weight is hydrostatically supported here. Besides the pump range CAM, also pump size CAM-Tandem can be erected vertically.

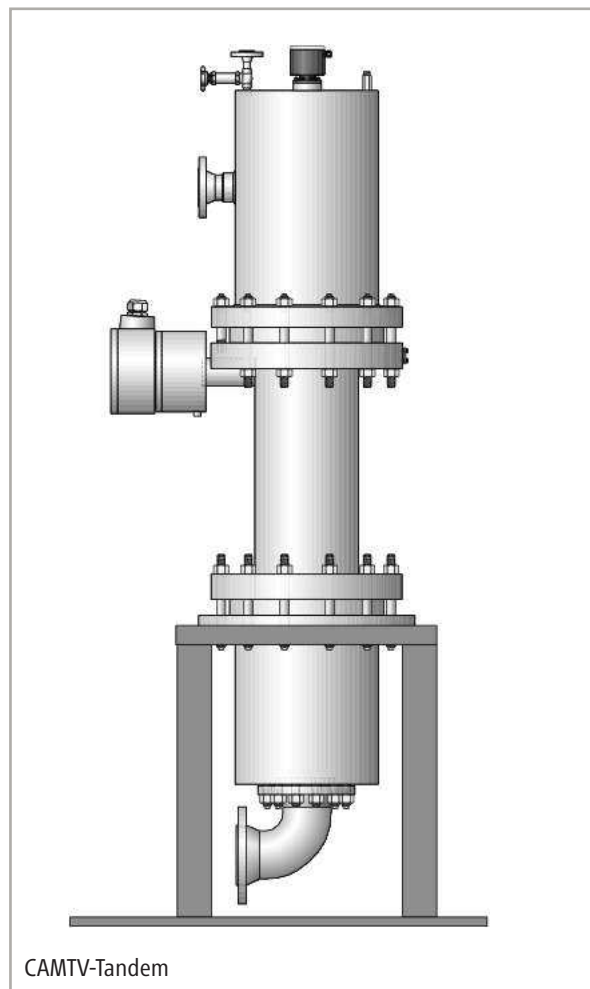
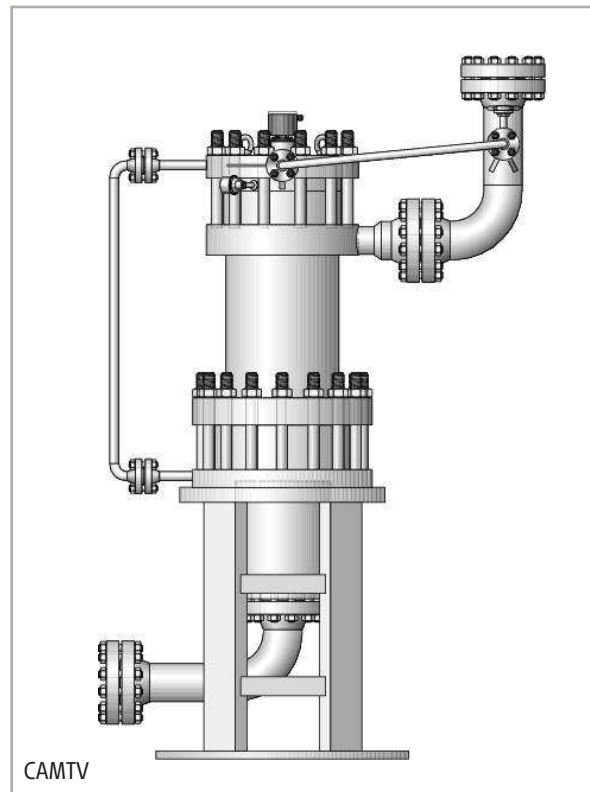

## Monitoring systems

The most part of HERMETIC pumps are designed according to explosion protection requirements. The pumps comply with the requirements of the electrical as well as mechanical explosion protection.

### Level monitoring:

On condition that the rotor cavity as part of the process system is steadily filled with liquid, no explosive atmosphere may arise. In this case, no accepted explosion protection is required for the rotor cavity. If the operator is not able to guarantee for a steady filling, it is necessary to install level monitoring devices.

### Temperature monitoring:

The observance of the temperature class and the maximum admissible surface temperature of the canned motor, respectively, is ensured via thermistor in the stator winding and/or via a measuring point on the bearing cover (liquid temperature).

### Monitoring of rotor position:

The axial thrust balancing is mainly influenced by the operating method of the pump, plant conditions and by various physical data of the liquid to be conveyed. For early detection of the source of errors, it is recommended to install a rotor-position-monitoring device. This electronic protective gear monitors the axial shaft clearance of the rotor, as well as its direction of rotation during operation in a hermetic and seal-less way. Together with the level and temperature monitoring, an effective and automatic early detection of failures may be achieved.

various monitoring devices			
①	Type N 30	LS	level
②	Type O 30	LS	
③	Type T 30	TS	temperature
④	Type KL 180	TS	
⑤	Type PT 100	TI	
⑥	Type ARM-2000 (4...20mA)	GI	rotor position/ direction of rotation
⑦	Type AM-2000	GI	

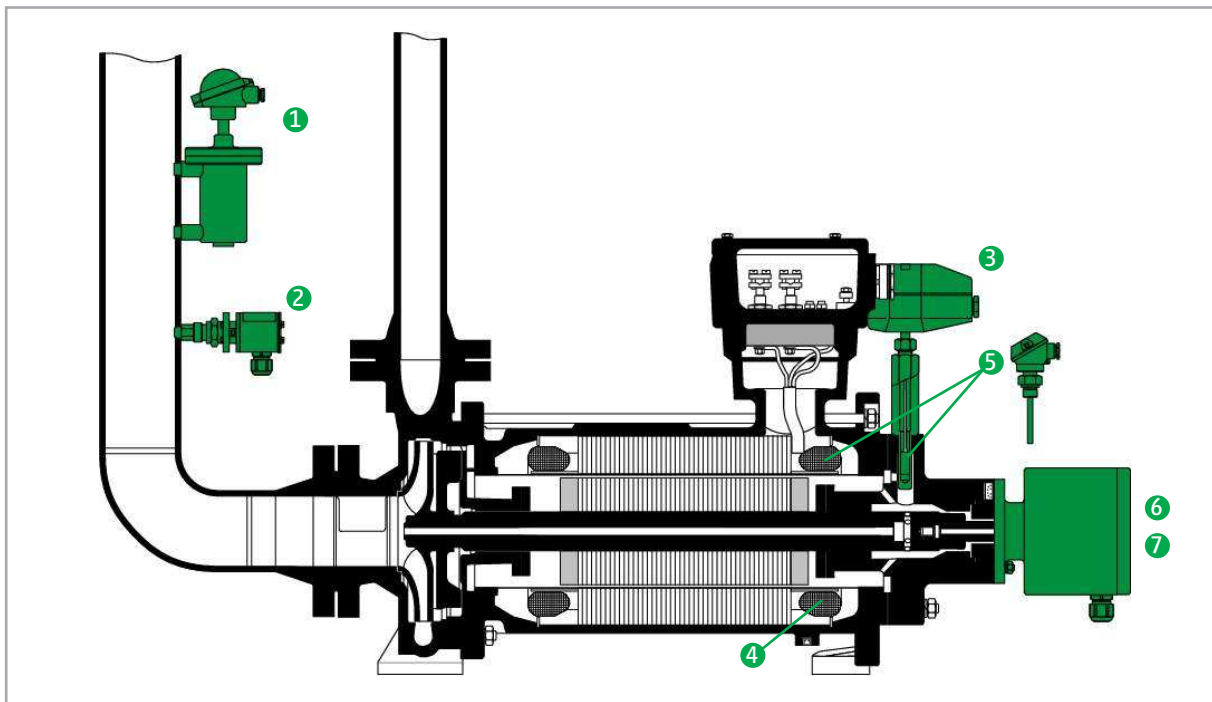

# Characteristics diagram

Characteristics diagram CAM – 3000 rpm 50 Hz

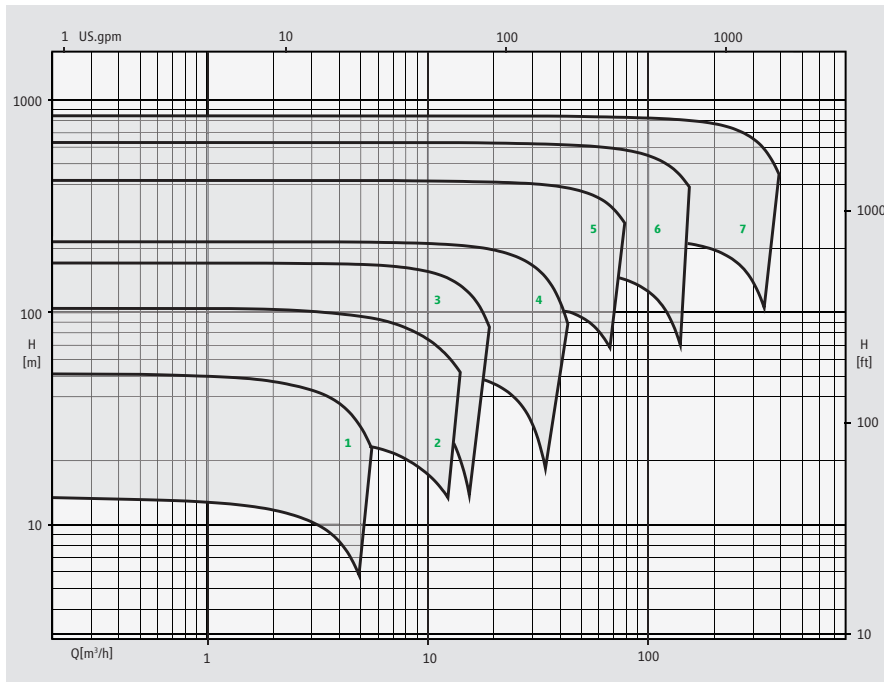

**Denomination of hydraulics to the characteristics diagram**

- 1** CAM 1 /2-6 stages
- 2** CAM 2 /2-6 stages
- 3** CAM 30 /2-6 stages
- 4** CAM 32 /2-6 stages
- 5** CAM 44 /2-6 stages
- 6** CAM 52 /2-6 stages
- 7** CAM 64 /2-6 stages

Characteristics diagram CAM-Tandem – 3000 rpm 50 Hz

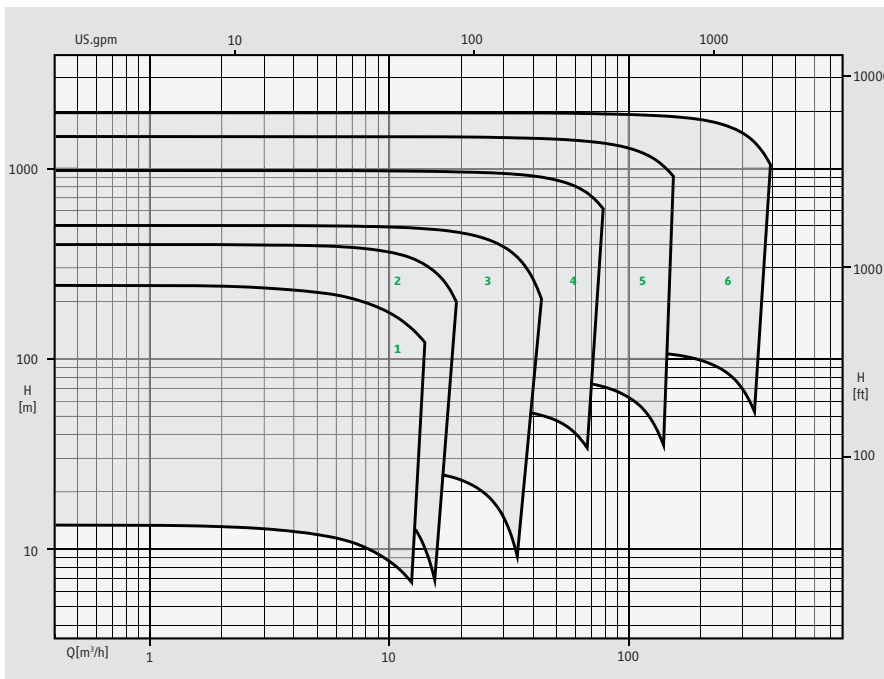

**Denomination of hydraulics to the characteristics diagram**

- 1** CAM 2 /1+0 to 7+7
- 2** CAM 30 /1+0 to 7+7
- 3** CAM 32 /1+0 to 7+7
- 4** CAM 44 /1+0 to 7+7
- 5** CAM 52 /1+0 to 7+7
- 6** CAM 64 /1+0 to 7+7

**Characteristics diagram CAM – 3600 rpm 60 Hz**

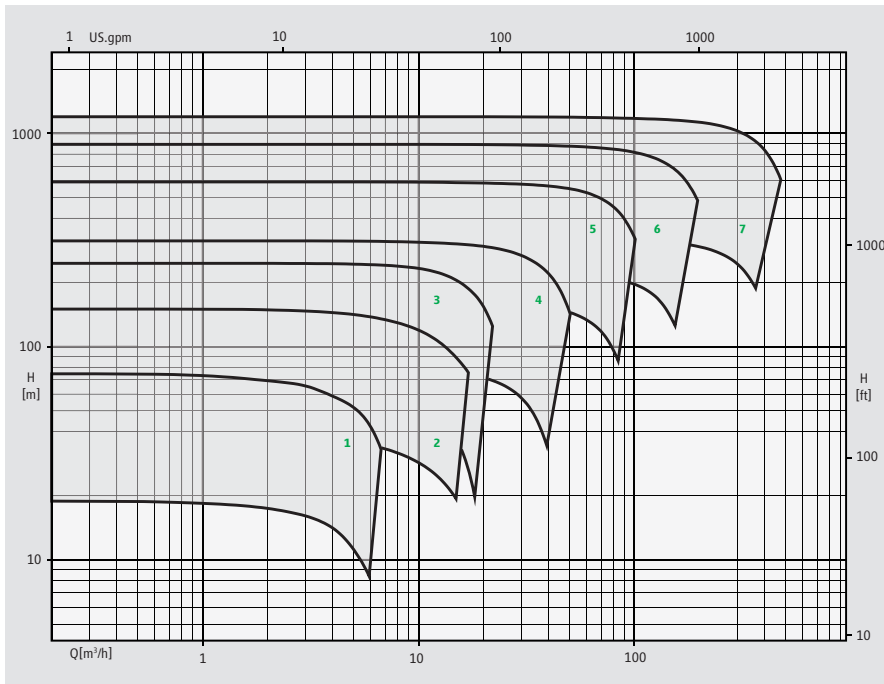

**Denomination of hydraulics to the characteristics diagram**

- 1** CAM 1 /2-6 stages
- 2** CAM 2 /2-6 stages
- 3** CAM 30 /2-6 stages
- 4** CAM 32 /2-6 stages
- 5** CAM 44 /2-6 stages
- 6** CAM 52 /2-6 stages
- 7** CAM 64 /2-6 stages

**Characteristics diagram CAM-Tandem – 3600 rpm 60 Hz**

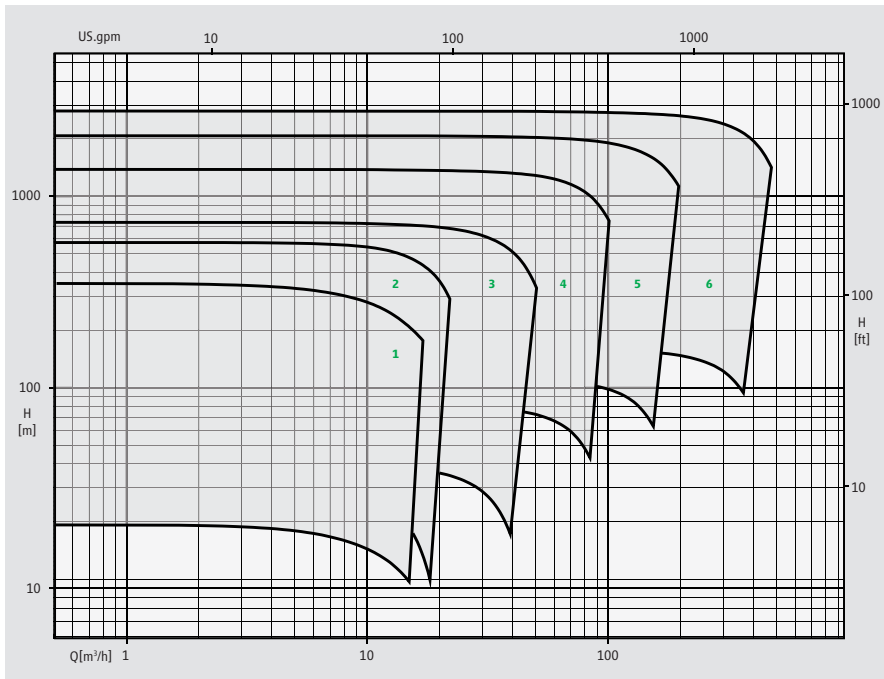

**Denomination of hydraulics to the characteristics diagram**

- 1** CAM 2 /1+0 to 7+7
- 2** CAM 30 /1+0 to 7+7
- 3** CAM 32 /1+0 to 7+7
- 4** CAM 44 /1+0 to 7+7
- 5** CAM 52 /1+0 to 7+7
- 6** CAM 64 /1+0 to 7+7

## Convincing service.

Important features are readiness, mobility, flexibility, availability and reliability. We are anxious to ensure a pump operation at best availability and efficiency to our customers.

### *Installation and commissioning:*

- service effected on site by own service technicians

### *Spare part servicing:*

- prompt and longstanding availability
- customized assistance in spare part stockkeeping

### *Repair and overhauling:*

- professional repairs including test run executed by the parent factory
- or executed by one of our service stations worldwide

### *Maintenance and service agreement:*

- concepts individually worked out to increase the availability of your production facilities

### *Training and workshops:*

- extra qualification of your staff to ensure the course of your manufacture

### **Our products comply with:**

- Explosion protection acc. to ATEX / UL / CQST / CSA
- VOC directive 1999/13/EC
- TA-Luft
- IPPC directive
- CE
- RCCM, level 2
- Rosgortechnazdor

### **HERMETIC-Pumpen GmbH**

#### **is certified acc. to:**

- ISO 9001:2000
- GOST "R"
- ATEX 94/9/EG
- AD HP 0 / TRD 201
- DIN EN 729-2
- KTA 1401, QSP 4a